

# AK PK3 M18 INDUCTIVE PROXIMITY SENSORS

Installation manual - 826004000 Rev. A - ENG - Created: 09/01/2023

## SUPPLIED MATERIAL

- Installation manual
- Safety instructions for dangerous areas
- CE Declaration of Conformity
- ATEX label marking

## GENERAL DESCRIPTION

- Wide range of models: standard, long distance, DOCOUT output
- Outputs: cable, M12 connector
- Models with 2, 3 and 4 wires
- Special models with double enclosure immersion proof (IP 68)
- Models with complementary output (NO+NC)
- CE Mark
- ATEX certified

## CONNECTIONS

### 3 wire version

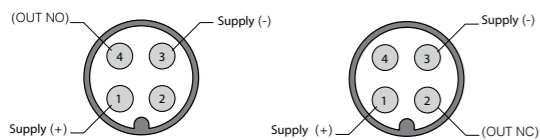

### 2 wire version



### Versions with complementary outputs

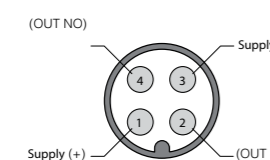

### PK3 DECOUT version

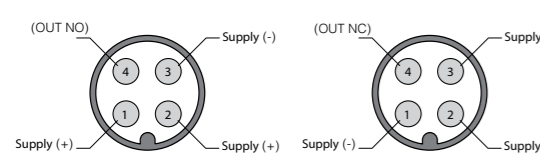

### PK3 DECOUT version

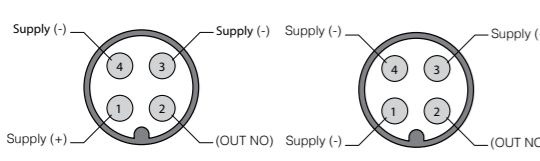

## ELECTRICAL DIAGRAMS

### 3 wire versions

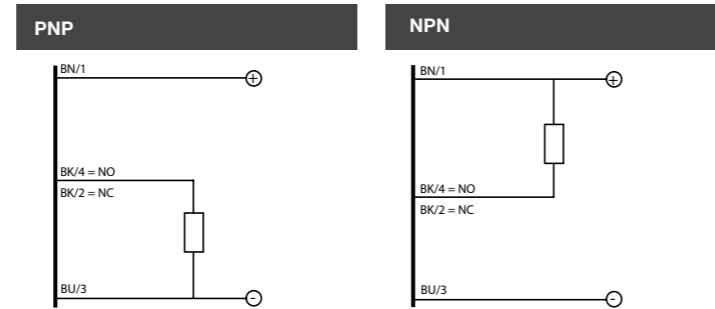

### 2 wire versions

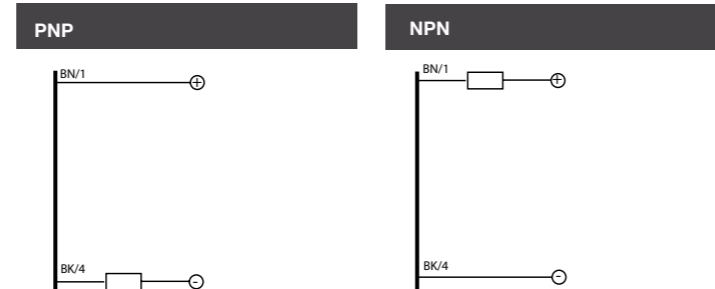

### Complementary outputs

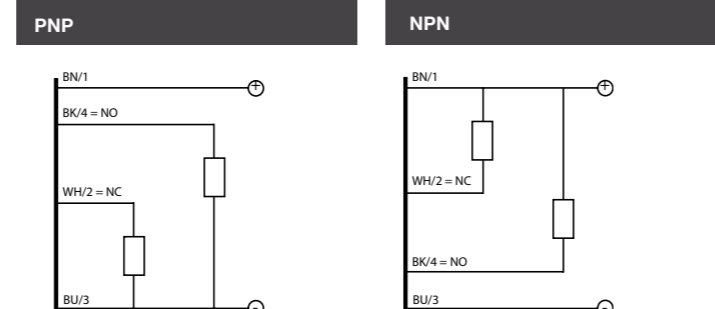

### PK3 DECOUT versions

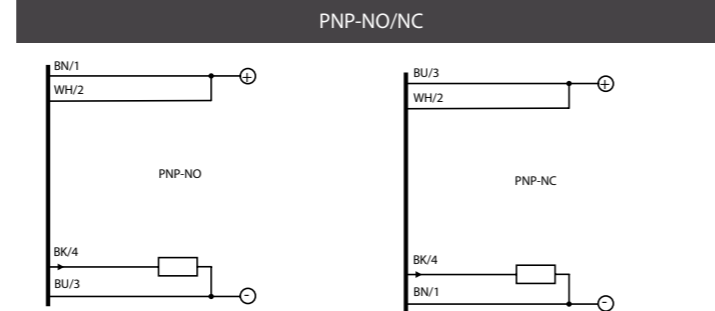

### PK3 DECOUT versions

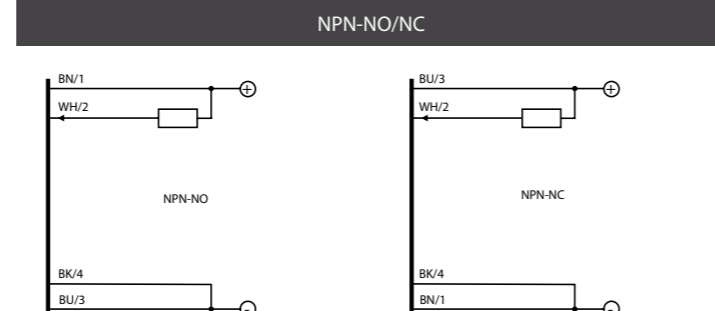

**KEY:** BN = brown; BK = black; BU = blue; WH = white.

## SPECIFICATIONS

Models	AK1*/**-1*	AK1*/**-2*	AK1*/**-3*	AK1*/**-4*	AK6*/**-1*	AK6*/**-2*	AK6*/**-3*	AK6*/**-4*	PK3/00-1*	PK3/00-2*
nominal sensing range	5 mm	8 mm	8 mm	12 mm	5 mm	8 mm	8 mm	12 mm	5 mm	8 mm
operating distance	0...4 mm	0...6.5 mm	0...6.5 mm	0...9.7 mm	0...4 mm	0...6.5 mm	0...6.5 mm	0...9.7 mm	0...4 mm	0...6.5 mm
hysteresis	0...20%									
standard target	18x18 mm FE 360	24x24 mm FE 360		36x36 mm FE 360	18x18 mm FE 360	24x24 mm FE 360		36x36 mm FE 360	18x18 mm FE 360	
repeat accuracy	5%				5% Ub 20-30V Ta=23°C±5°C				5%	
supply voltage range	10...30 Vcc									
max. ripple content	≤ 10 %									
output current	≤ 400 mA ( 3...100 mA for 2 wire versions)				≤ 400 mA				≤ 100 mA	
output voltage drop	≤ 1V @ 400 mA (2.8 V @ 100 mA for 2 wire versions)				≤ 1.5 V @ 400 mA				≤ 1.2 V @ 100 mA	
no load supply current	20 mA				≤ 10 mA				30 mA	
output logic	-				PNP or NPN				-	
output status	-				NO or NO+NC				-	
leakage current	10 µA (0.8 mA for 2 wire versions)				10 µA				-	
switching frequency	600 Hz (300 Hz for 2 wires)		300 Hz (150 Hz for 2 wires)		2.5 KHz		2 KHz		2 KHz	
time delay before availability	≤ 50 ms									
temperature range	-25°C ÷ +70°C									
temperature drift	10%				≤ 10%				10%	
short-circuit protection	●				● (self-restoring)				●	
induction protection	-				●				-	
voltage reversal protection	-				●				-	
EMC	conforming to EMC Directive requirements according to IEC 60947-5-2									
shocks and vibrations	IEC 60947-5-2									
weight	30 g connector version 55 g cable version				-				30 g connector version 70 g cable version	
protection rating	IP67									
housing material	nickel-plated brass								nickel-plated brass (INOX for W versions)	
sensing face material	PBT									
LED indicators	yellow LED output state				enabled output (yellow LED)					
connection	M12 connector, 2 m PVC cable output									
tightening torque	25 Nm				1.5 Nm (plastic) / 100 Nm (metal)				25 Nm	

## CODE DESCRIPTION



## PK3 Series

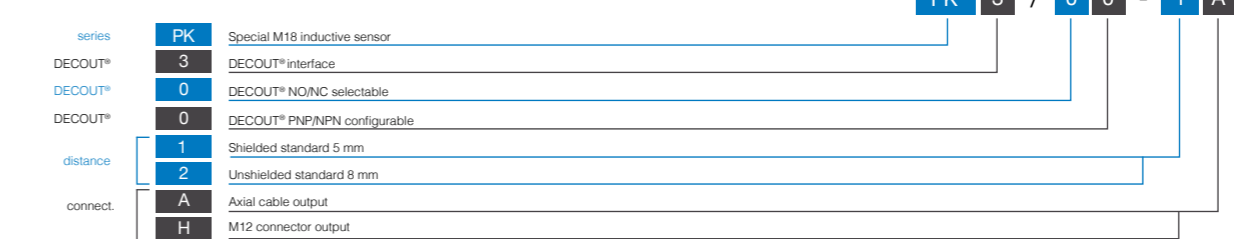

**Micro Detectors**  
Italian Sensors Technology

CE  
Ex  
AK model  
II 3G Ex nA IIC T6 Gc  
II 3D Ex tc IIIB T85°C Dc  
Certificate no.: 0802009X

PK3 model  
II 3G Ex nA IIC T6 Gc  
II 3D Ex tc IIIB T85°C Dc  
Certificate no.: 0802010X

WARNING These products are NOT safety sensors and are NOT suitable for use in personal safety application.

For ATEX models read carefully safety instruction before installation.

**Declaration of conformity**  
Datsensing S.r.l. declares under our sole responsibility that these products are in conformity with the EMC directive.

Datsensing S.r.l.  
Strada S. Caterina 235 - 41122 Modena - Italy  
Tel. +39 059 420411 - Fax +39 059 253973 -  
[www.datsensing.com](http://www.datsensing.com)

## RESPONSE DIAGRAM

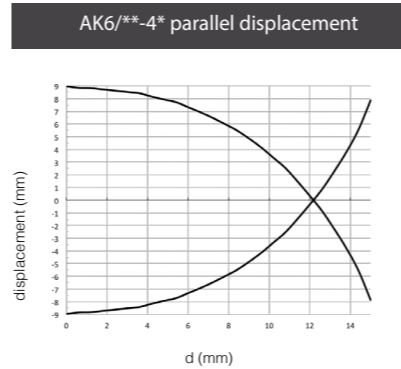
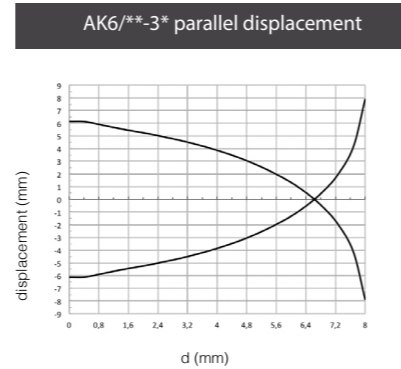
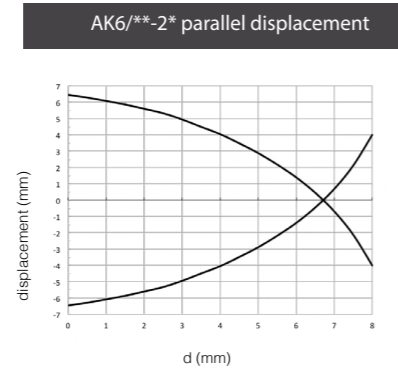
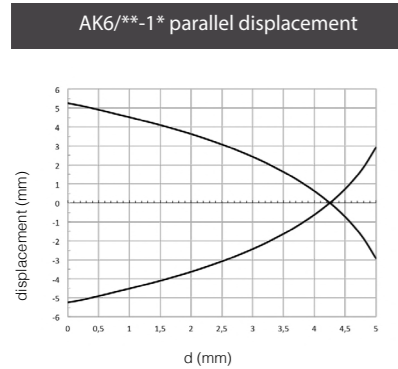
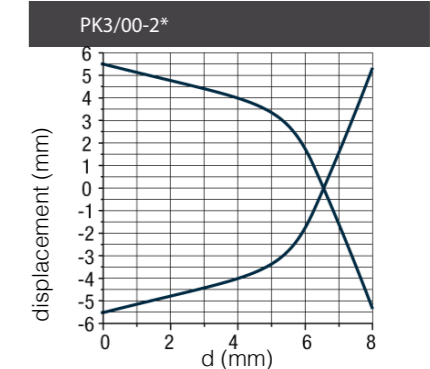
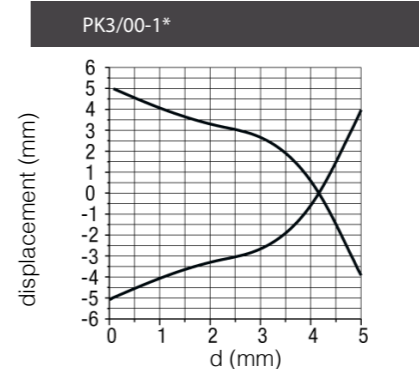
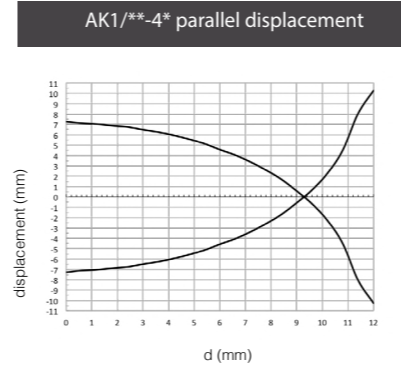
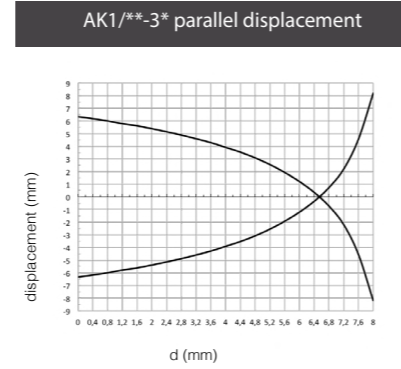
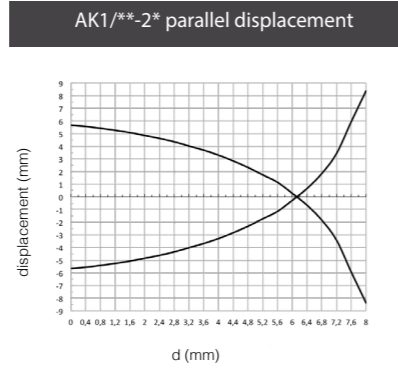
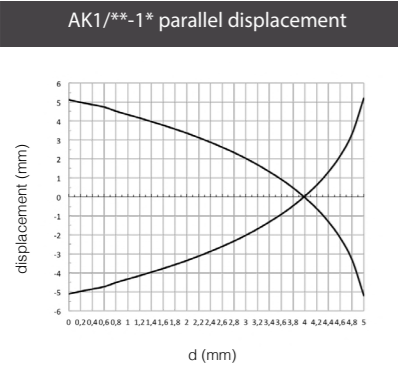

## MOUNTING

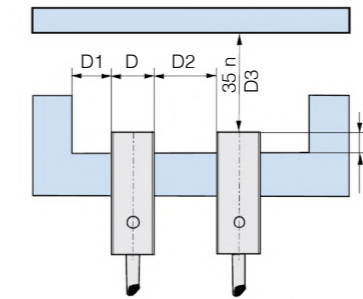

code	D4	D1	D2	D3
AK**-1*	≥ 3.6 mm	≥ 9 mm	≥ 18 mm	≥ 15 mm
AK**-2*	≥ 16 mm	≥ 18 mm	≥ 36 mm	≥ 24 mm
AK1**-3*	≥ 3.6 mm	≥ 9 mm	≥ 18 mm	≥ 15 mm
AK1**-4*	≥ 16 mm	≥ 18 mm	≥ 36 mm	≥ 24 mm
AK6**-1*	≥ 3.6 mm	≥ 9 mm	≥ 18 mm	≥ 15 mm
AK6**-2*	≥ 12 mm	≥ 18 mm	≥ 36 mm	≥ 24 mm
AK6**-3*	≥ 1.8 mm <sup>(1)</sup>	≥ 9 mm	≥ 18 mm	≥ 24 mm
AK6**-4*	≥ 16 mm	≥ 18 mm	≥ 36 mm	≥ 36 mm
PK3/00-1*	≥ 3.6 mm	≥ 9 mm	≥ 18 mm	≥ 15 mm
PK3/00-2*	≥ 16 mm	≥ 18 mm	≥ 36 mm	≥ 24 mm

(1) ≥ 2.6 mm for non-magnetic materials

## DIMENSIONS (mm)

AK1/\*\*-1A  
AK1/\*\*-3A

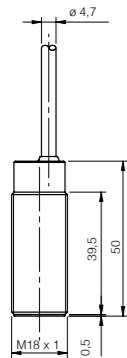

AK1/\*\*-1B  
AK1/\*\*-3B

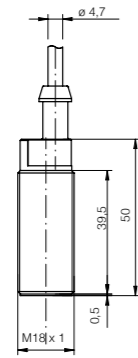

AK1/\*\*-1D  
AK1/\*\*-3D

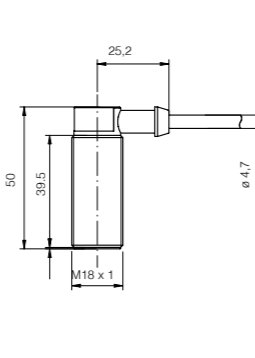

AK1/\*\*-1H  
AK1/\*\*-3H

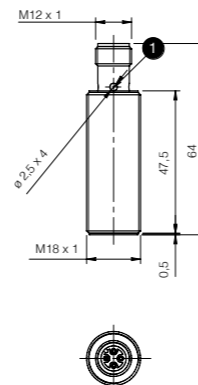

AK1/\*\*-2A  
AK1/\*\*-4A

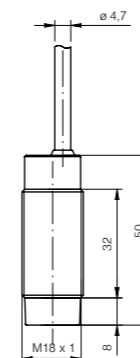

AK1/\*\*-2B  
AK1/\*\*-4B

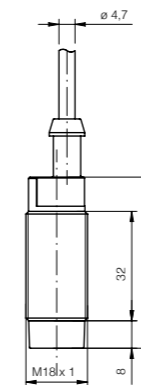

AK1/\*\*-2C  
AK1/\*\*-4C

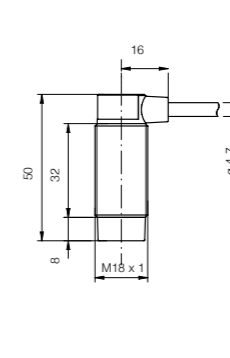

AK1/\*\*-2H  
AK1/\*\*-4H

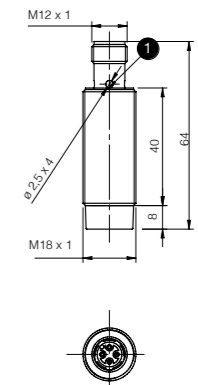

AK6/\*\*-1A  
AK6/\*\*-3A

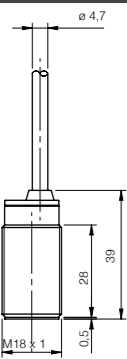

AK6/\*\*-1H  
AK6/\*\*-3H

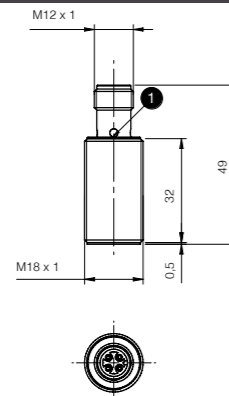

AK6/\*\*-2A  
AK6/\*\*-4A

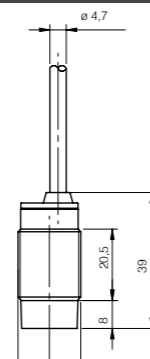

AK6/\*\*-2H  
AK6/\*\*-4H

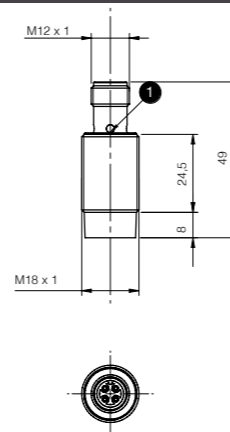

PK3/00-1A

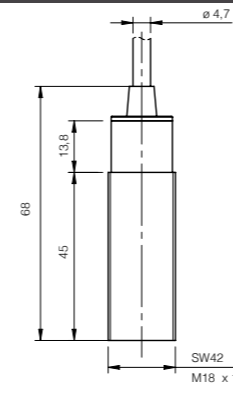

PK3/00-1H

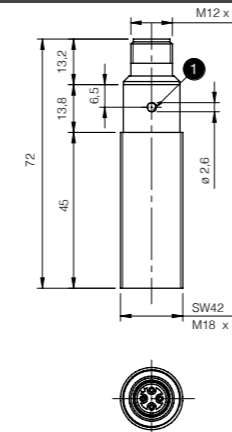

PK3/00-2A

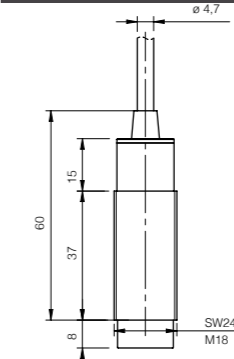

PK3/00-2H

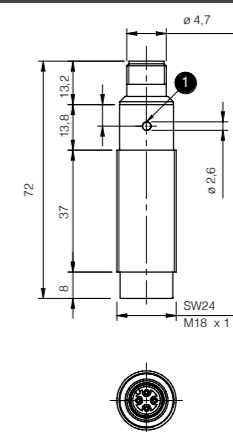

1 LED



**Micro Detectors**  
Italian Sensors Technology



AK model  
II 3G Ex nA IIC T6 Gc  
II 3D Ex tc IIIB T85°C Dc  
Certificate no.: 0802009X

PK3 model  
II 3G Ex nA IIC T6 Gc  
II 3D Ex tc IIIB T85°C Dc  
Certificate no.: 0802010X

**WARNING** These products are NOT safety sensors and are NOT suitable for use in personal safety application.

For ATEX models read carefully safety instruction before installation.

**Declaration of conformity**  
Datasensing S.r.l. declares under our sole responsibility that these products are in conformity with the EMC directive.

Datasensing S.r.l.  
Strada S. Caterina 235 - 41122 Modena - Italy  
Tel. +39 059 420411 - Fax +39 059 253973 -  
[www.datasensing.com](http://www.datasensing.com)