

# Actuator LD36



LD36 is a compact actuator with IP66 protection level, suitable for various applications with limited installation space, such as window opener, adjustable car driver seat, and other outdoor applications.

## Content

<b>Features and Options</b>	<b>3</b>
<b>Performance Data</b>	<b>4</b>
<b>Dimensions</b>	<b>5</b>
1. Installation dimension	5
2. Drawing	5
3. Front connector type	6
4. Rear connector type	6
<b>Compatibility</b>	<b>7</b>
<b>Cable Plug</b>	<b>7</b>
<b>Cable with Flying Leads</b>	<b>8</b>
1. Basic, without positioning feedback.	8
2. With Potentiometer (POT) absolute positioning feedback	8
3. With 60V dual Hall effect sensors positioning feedback	9
<b>Ordering Key</b>	<b>10</b>
<b>Certifications</b>	<b>11</b>

## Features and Options

---

- Main applications: Industry / Furniture
- Input voltage: 12V DC / 24V DC
- Max. load: 1000N (Push / Pull)
- Max. speed at no load: 43.9mm/sec (Typical value)
- Speed at full load: 4.6mm/sec (Typical value @1000N loaded)
- Stroke: 50 / 100 / 150 / 200 / 250 / 300mm
- Noise level:  $\leq 60$ dB
- IP level: IP66 / IP69K (Static; no-action)
- Preset limit switches
- Positioning:
  - Optional digital positioning feedback with dual Hall effect sensors
  - Optional analog positioning feedback with Potentiometer (POT)
- Duty cycle: 25%, max. 1 min. continuous operation in 4 min.
- Operating ambient temperature:  $-25^{\circ}\text{C} \sim +65^{\circ}\text{C}$  (Full performance  $+5^{\circ}\text{C} \sim +40^{\circ}\text{C}$ )
- Storage ambient temperature:  $-25^{\circ}\text{C} \sim +65^{\circ}\text{C}$
- Certified: CE Marking, Electromagnetic Compatibility Directive 2014/30/EU (for 24V DC only)



## Performance Data

Model No.	Gear ratio	Max. Push/Pull load (N)	Max. static load (N)	Typical speed (mm/s) <sup>(1)</sup>		Typical current (A) <sup>(1)</sup>			
				No load	Full load	No load		Full load	
						12V	24V	12V	24V
LD36-XX-05-XXX	5:1	150	250	43.9	30.8	1.0	0.5	2.4	1.2
LD36-XX-10-XXX	10:1	250	340	27.6	16.8	1.0	0.5	2.4	1.2
LD36-XX-20-XXX	20:1	500	680	14.6	9.5	1.0	0.5	2.4	1.2
LD36-XX-30-XXX	30:1	800	1020	9.5	6.3	1.0	0.5	2.4	1.2
LD36-XX-40-XXX	40:1	1000	1530	7.0	4.6	1.0	0.5	2.4	1.2

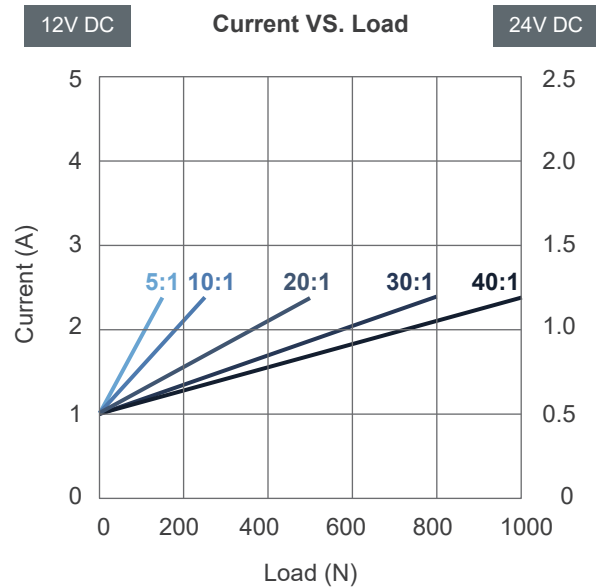
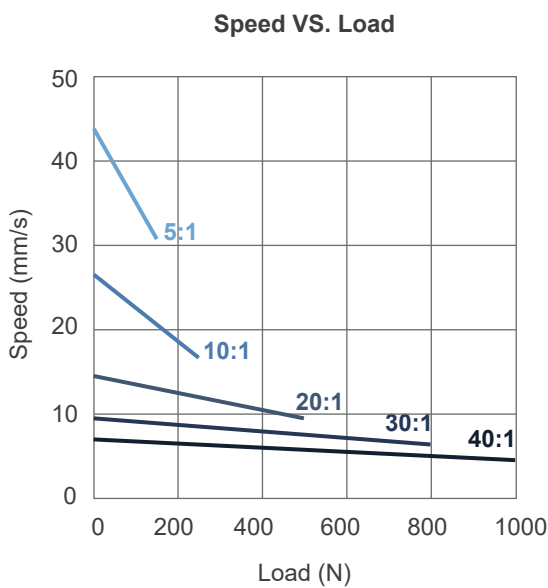

### Note:

<sup>(1)</sup> The typical speed or typical current means the average value neither upper limit nor lower limit, which measured under room temperature and stable power. The performance curves are made with typical values.

### • Inrush current



- When the actuator starts to operate, an inrush current of about 0.2 seconds will be generated. The starting inrush current of LD36 can reach about 3 times of the typical current under the actuator load.
- If a circuit board power supply is used, the specifications must be sufficient to handle the inrush current. If batteries are used as the power source, inrush current will not be a problem.
- MOTECK controllers are designed to take into account the inrush current when the actuator starts. If the user provides his or her own controller, this feature must be considered in the specifications and protection mechanisms. Besides, the connectors, switches and relays selected by users must also be able to withstand the starting currents.



## Dimensions

### 1. Installation dimension

- Retracted length (A)

(tolerance:  $\pm 3\text{mm}$ )

	Option	Front connector code	Stroke (S)					
			50	100	150	200	250	300
Retracted length (A)	Basic or with Hall sensor	1	158	209	260	311	362	413
		3	199	250	301	352	403	454
		6	168.5	219.5	270.5	321.5	372.5	423.5
	With POT	1	195	246	297	348	399	450
		3	236	287	338	389	440	491
		6	205.5	256.5	307.5	358.5	409.5	460.5

- Extended length = Retracted length (A) + Stroke (S)

**Note:** The dimension "A" is shown in page 5 & 6, as indicated in the figure below.

### 2. Drawing

- Basic, without positioning feedback.

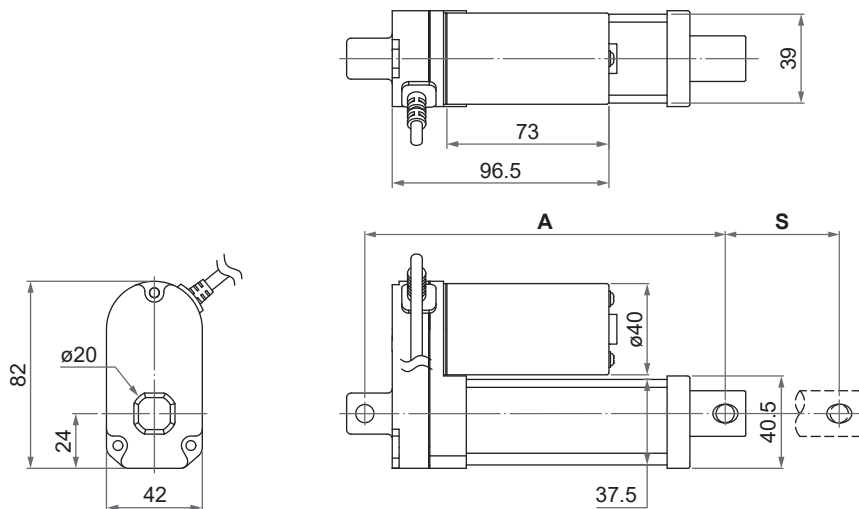

- With dual Hall effect sensor positioning feedback

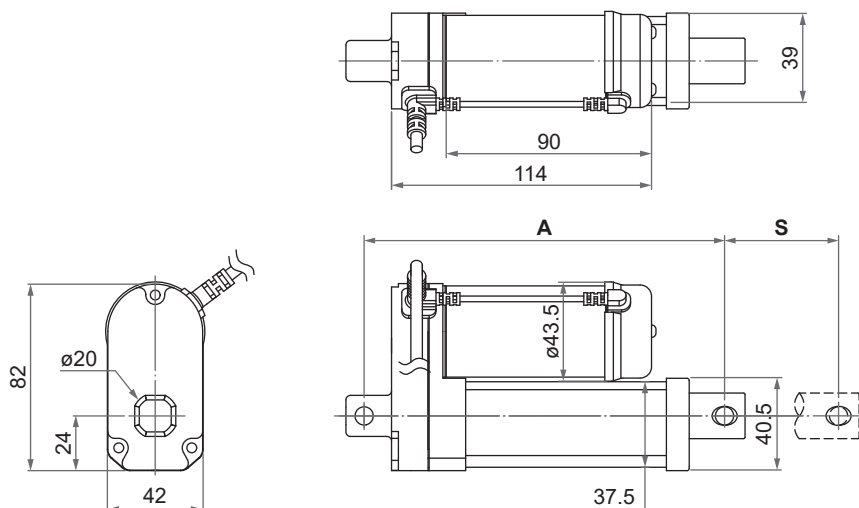

Unit: mm



- With potentiometer (POT) absolute positioning feedback

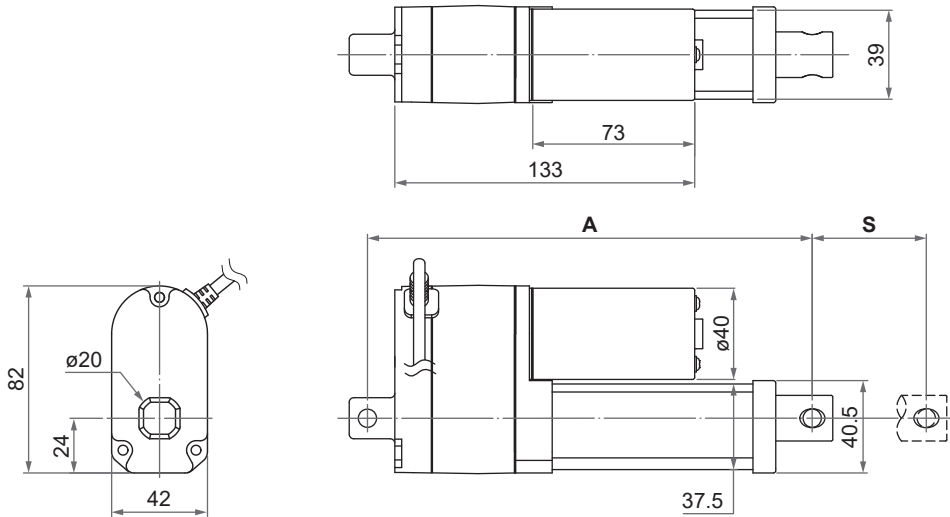

### 3. Front connector type

1: Drilled hole

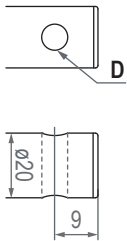

3: Spherical rod eye

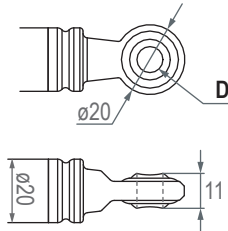

6: Plastic slot

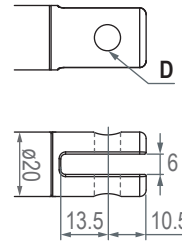

Front connector code	Diameter of pivot without bushing (D)
1	ø6.4, ø8, ø10
3	ø8
6	ø8, ø10

### 4. Rear connector type

0: Zinc alloy clevis, 0°

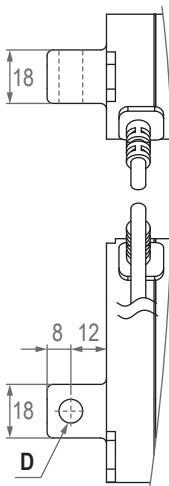

9: Zinc alloy clevis, 90°

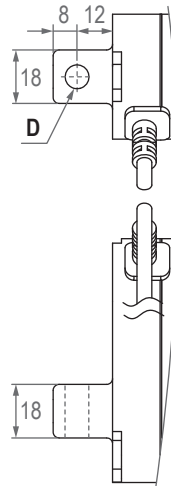

Rear connector code	Diameter of pivot without bushing (D)
0, 9	ø6.4, ø8, ø10

Unit: mm



## Compatibility

Product	Model	LD36 spec
<b>Controller</b>	CI72	<ul style="list-style-type: none"> <li>• All standard positioning feedback option</li> <li>• Cable with flying leads</li> </ul>
	CI73	<ul style="list-style-type: none"> <li>• With dual Hall effect sensors for positioning</li> <li>• Cable with flying leads</li> </ul>
	CI74	<ul style="list-style-type: none"> <li>• With dual Hall effect sensors for positioning</li> <li>• With minifit 6-pin plug</li> </ul>
<b>Accessory</b>	MB22 mounting bracket (Fig. 1)	Standard, mounting hole $\varnothing 6.4\text{mm}$ , $\varnothing 8\text{mm}$ or $\varnothing 10\text{mm}$



Fig. 1

## Cable Plug

- Positioning feedback with dual Hall effect sensors

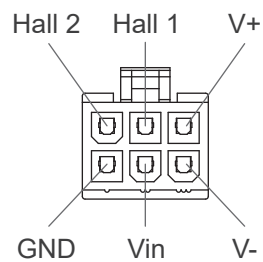

With minifit 6-pin plug



Minifit plug

## Cable with Flying Leads

### 1. Basic, without positioning feedback.

	Wire color	Definition	Descriptions
Power wires	Red	DC power	Connect red wire to "Vdc +" & black wire to "Vdc -" of 12 or 24V DC power to extend the actuator. Switch the polarity of DC input to retract it.
	Black		

### 2. With Potentiometer (POT) absolute positioning feedback

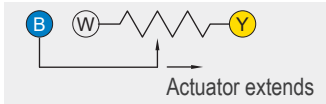
	Wire color	Definition	Descriptions														
Power wires	Red	DC power	Connect red wire to "Vdc +" & black wire to "Vdc -" of 12 or 24V DC power to extend the actuator. Switch the polarity of DC input to retract it.														
	Black																
Signal wires	Yellow	Vin	Input voltage 70V max.														
	Blue	POT output	<p>1. Potentiometer specification:</p> <ul style="list-style-type: none"> <li>- 10K ohm, 10 turns.</li> <li>- Total resistance tolerance <math>\pm 5\%</math></li> <li>- Independent linearity <math>\pm 0.25\%</math></li> </ul> <p>2. Output voltage: The voltage (resistance) between blue and white increases linearly from about 0 when the actuator extends, and decreases when it retracts.</p>  <p>3. There are different resolutions according to the stroke length (as table below)</p> <table border="1"> <thead> <tr> <th>Stroke</th> <th>Resistance (tolerance: <math>\pm 0.3K\Omega</math>)</th> </tr> </thead> <tbody> <tr> <td>50mm</td> <td>0.3~4.8K</td> </tr> <tr> <td>100mm</td> <td>0.3~5.0K</td> </tr> <tr> <td>150mm</td> <td>0.3~4.5K</td> </tr> <tr> <td>200mm</td> <td>0.3~4.9K</td> </tr> <tr> <td>250mm</td> <td>0.3~4.8K</td> </tr> <tr> <td>300mm</td> <td>0.3~4.8K</td> </tr> </tbody> </table> <p>4. The potential value can be measured through the POT output and GND wires.</p>	Stroke	Resistance (tolerance: $\pm 0.3K\Omega$ )	50mm	0.3~4.8K	100mm	0.3~5.0K	150mm	0.3~4.5K	200mm	0.3~4.9K	250mm	0.3~4.8K	300mm	0.3~4.8K
			Stroke	Resistance (tolerance: $\pm 0.3K\Omega$ )													
			50mm	0.3~4.8K													
100mm	0.3~5.0K																
150mm	0.3~4.5K																
200mm	0.3~4.9K																
250mm	0.3~4.8K																
300mm	0.3~4.8K																
White	GND																

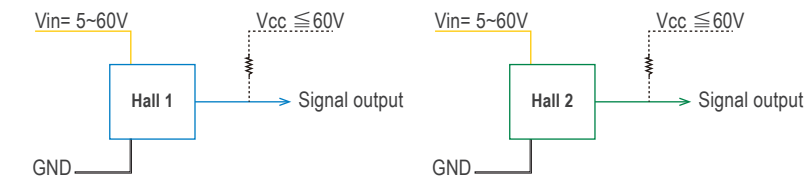
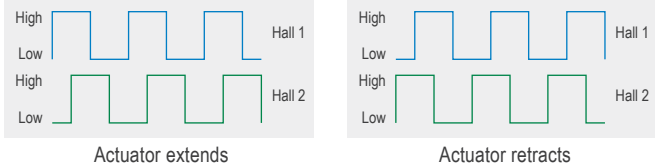
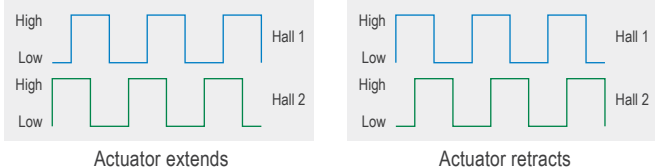

### 3. With 60V dual Hall effect sensors positioning feedback

	Wire color	Definition	Descriptions																		
Power wires	Red	DC power	Connect red wire to "Vdc +" & black wire to "Vdc -" of 12 or 24V DC power to extend the actuator. Switch the polarity of DC input to retract it.																		
	Black																				
Signal wires	Yellow	Vin	<p>Voltage input range: 5~60V</p> <p> If this voltage input must share the motor's power supply, be sure to use a separate power cord to draw power from the source, not tapping it from the control board's power input. Otherwise, the motor's inrush current will cause the Hall IC circuit to malfunction.</p>																		
	Blue	Hall 1 output	<p>The default Hall signal is NPN type without pull-up resistor. The signal output wires should connect a pull-up resistor to the operating voltage (Vcc) of the system. (10KΩ resistor is recommended, or the result of the voltage of Vcc divided by the resistance of the pull-up resistor is lower than 20mA)</p> <p>Wiring:</p>  <p>High= Determined by Vcc and the pull-up resistor. Low= GND</p> <p>Hall signal data:</p> <ul style="list-style-type: none"> <li>- A type</li> </ul>  <ul style="list-style-type: none"> <li>- B type</li> </ul>  <p>Hall effect sensor resolution:</p> <table border="1"> <thead> <tr> <th>Gear ratio</th> <th>Resolution (pulses/mm)</th> <th>Hall signal data type</th> </tr> </thead> <tbody> <tr> <td>5:1</td> <td>1.14</td> <td>B type</td> </tr> <tr> <td>10:1</td> <td>1.81</td> <td>A type</td> </tr> <tr> <td>20:1</td> <td>3.43</td> <td>A type</td> </tr> <tr> <td>30:1</td> <td>5.29</td> <td>A type</td> </tr> <tr> <td>40:1</td> <td>7.14</td> <td>B type</td> </tr> </tbody> </table>	Gear ratio	Resolution (pulses/mm)	Hall signal data type	5:1	1.14	B type	10:1	1.81	A type	20:1	3.43	A type	30:1	5.29	A type	40:1	7.14	B type
	Gear ratio	Resolution (pulses/mm)	Hall signal data type																		
	5:1	1.14	B type																		
10:1	1.81	A type																			
20:1	3.43	A type																			
30:1	5.29	A type																			
40:1	7.14	B type																			
Green	Hall 2 output																				
	White	GND																			

**Note:** The single Hall option is no longer provided starting from Dec. 1st 2024



## Ordering Key

		LD36- 24 - 05 - 150 - 1 0 H 0 0
<b>Input voltage</b>	12: 12V DC 24: 24V DC	
<b>Gear ratio</b>	05: 5:1 10: 10:1 20: 20:1 30: 30:1 40: 40:1	
<b>Stroke</b>	050: 50mm 100: 100mm 150: 150mm 200: 200mm 250: 250mm 300: 300mm	
<b>Front connector type</b> (Refer to Page 6)	1: Drilled hole 3: Spherical rod eye 6: Plastic slot	
<b>Rear connector type</b> (Refer to Page 6)	0: Zinc alloy clevis, 0° 9: Zinc alloy clevis, 90°	
<b>Positioning feedback</b>	0: None P: Potentiometer (POT) H: 60V dual Hall effect sensors	
<b>Reserved</b>	0	
<b>Cable length</b>	0: 900mm straight 1: 1500mm straight 2: 2000mm straight	



## Certifications

---

LD36 actuator is compliant with the following regulations, in terms of the essential conformity requirements of EMC Directive of 2014/30/EU.

Emission	Immunity
EN 55014-1:2017+A11:2020	EN 55014-2:2015

---

### Terms of Use

The user is responsible for application suitability of Moteck products. As ongoing improvement process continues, products listed on the Moteck website are subject to change without prior notice. Moteck reserves the right to terminate the sales or remove any product displayed on the website, or listed in its catalogues.

